



**UPCOMING
EVENTS**

July 4th

Stated Meeting

July 11th

FC Degree

July 18th

MM Degree

July 25th

Education Night

[Online Calendar](#)

INSTALLATION OF OFFICERS



On Saturday, June 29th, the officers of Plano Masonic Lodge were installed by Joe Moses (Master), Mike Heidenreich (Marshal) and Bob Pannell (Chaplain).

A special thanks to the installation team and the brethren, friends and family who attended the installation!



Visit (and be sure to LIKE) our [PUBLIC PAGE](#)

Request to join our [GROUP PAGE](#)

FROM THE EAST

Brethren,

As we begin a new Masonic year, I want to thank everyone for their support. I'm looking forward to continuing the work started by our immediate Past Masters and building upon their foundation. As many of you know, I am very interested in Masonic education and research. It is my intent that the Lodge stay busy during the year; if we aren't conferring a degree, we will be presenting an educational program related to Masonic history, symbolism or research. I also think that it is important that we provide a good experience for our candidates when conferring degrees. I strongly encourage everyone interested in working in the degrees to participate in our practice sessions. If you are interested in taking a part, please see me or Brother Marshall. I will be coordinating forthcoming activities with the Lodge Officers and will have a detailed presentation for the next Trestleboard. If anyone has any concerns or request, please see me or either one of the Wardens.

Fraternally,

Bill Goodell, Worshipful Master

Committee on Work

CERTIFICATE EXAMINATION PRACTICES

Ricky Brown with the Grand Lodge Committee on Work is scheduled to conduct the Certificate Exam at Plano Lodge on Monday, September 9th at 6:00 p.m. Lecture practice sessions for "A" CERTIFICATE CANDIDATES will be held each Wednesday preceding Monthly Stated meeting beginning at 6:30 PM in the Lodge room.

NOTE: Floor-work, Opening/Closing, and Q&A will be practiced on remaining Wednesday nights prior to Called meetings as part of degree team practice.

As a reminder, here are the requirements for each class:

- **"C" Certificate** – Questions and answers from all three Degrees, the Tiler's Oath, and how to open, close, and call to and from labor all three Lodges and the Master Mason's Lodge of Sorrow
- **"B" Certificate** – All requirements for "C" certificate and the floor work for all three Degrees
- **"A" Certificate** - All requirements for "B" certificate and the short-form lectures for all three Degrees

Contact Jim Harbor at jim.harbor@gmail.com or 469-744-6028 for more information.

BLOOD

The Gift Of Life

The "Gift of Life" program sponsored by the Grand Lodge of Texas helps children throughout the Lone Star State. Texas Scottish Rite Hospital for Children in Dallas, the Shrine Burn Center in Galveston, and the Shrine Orthopedic Hospital in Houston require approximately 9,000 units of blood each year. Statistics show that the population of Texas uses more blood and blood products than its citizens are donating; therefore, blood is being imported into the state from other areas of the country. This places our hospitals in the position of bargaining for available blood with every other hospital in the state. In some cases, medical personnel have had to resort to walking the halls to secure blood donors for necessary surgeries.

The Gift of Life program in Texas is meeting the blood requirements of our hospitals and providing an annual surplus to be used in emergencies, both public and fraternal.

This not only meets an essential need for our hospitals but also helps our communities by making fresh blood available whenever it is needed and by providing an easy means of donation. It is important to understand that the Gift of Life program is not designed to secure donations only from Masons. All donations are important and welcome. The strength of the Gift of Life effort is in providing an easy opportunity for the general public to donate through our Masonic Lodges. There is a Masonic Lodge nearby for everyone in the state, and we have found that people want to donate blood, especially when children are involved. By providing an easy means of donation, with the proper publicity, we can easily provide 20,000 units of blood annually. By unifying all of the Masonic Lodges in Texas under the common Gift of Life banner, we all gain the benefit of each local drive's publicity. We do this annually each fall. This provides fresh blood when the supplies are most critical and when demand is at its peak. The program also gives the public a sense of what Freemasons do in the community, especially our help for children.

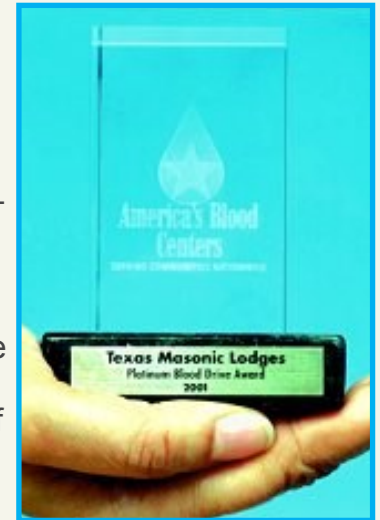

To date, the Gift of Life program has produced the following results:

- Thousands of units of blood have been collected.
- Lodges have been visited by hundreds of non-Masons.
- Several petitions for membership have been received.
- Local Masons have demonstrated to their community the viability and involvement of the Masonic Fraternity.

Today, the Gift of Life effort is making a difference, and we all win-our hospitals, our communities, our Lodges and, most importantly, the children we serve. There are no losers. **You, too, can be a winner by participating in the Plano Lodge Blood Drive – October 26, 2013.**

The South at Meridian Height

By Bro. Barry Parrish, Junior Warden

“There are therefore three principals: God, the substance of things, and form. God is the artist, the mover; the substance is the matter moved; the essence is what you might call art, and that to which the substance is brought by the mover. But since the mover contains forces which are self-contrary, those simple bodies, and as the contraries are in need of principle harmonizing and unifying them, it must necessarily receive its efficacious virtues and proportions from the numbers, and all that is manifested in numbers and geometric forms; virtues and propositions capable of binding and uniting into form the contraries that exist in the substance of things.”

Archytas of Tarentum, *Fragments of Pythagoras*, (400 B.C.)

Although the sun passes light in all directions, there are 4 main cardinal points on Earth where they are simultaneously received: North, South East and West.

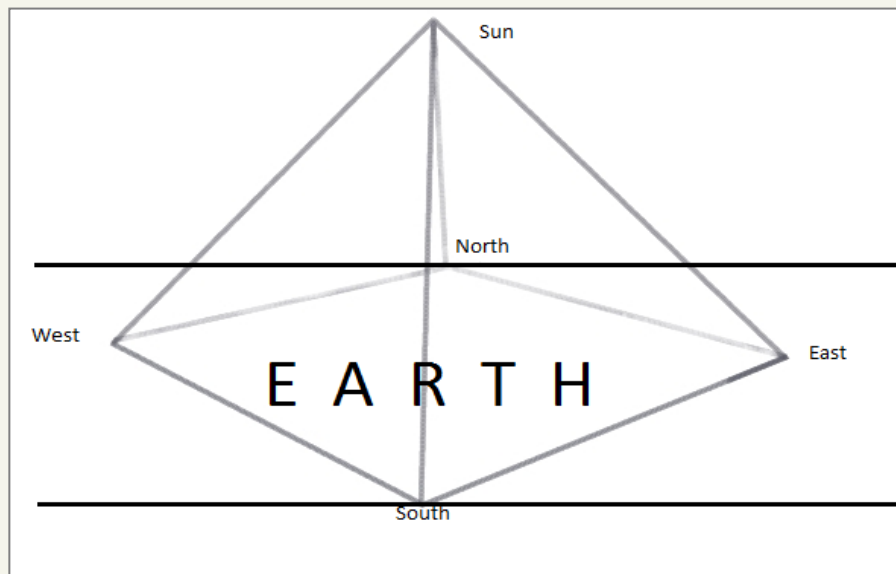

They all form horizontal, perpendicular and right angles from the zenith of the Sun to the points where they touch. Except for cloud cover, these rays are permanently observable and immovable because if you visualize the lines continuing through Earth to Nadir (the point of the celestial sphere that is directly opposite the zenith and vertically downward from the observer). The Plumb, Level and Square, masonically, are immovable jewels of the Lodge. Assuming the Lodge is geometrically represented as the Earth, the immovable jewels represent the right angles of the zenith.

Pre-Pythagoras, before the age of Enlightenment, as the sun passed from East to West in plane geometry, it was conceived to be at a right angle to the surface, North and South traveled East to West in parallel lines. The Earth being thought stationary and the Sun revolving around it, reaching a zenith and illustrating a Plumb line from theoretical North to South, a 90 degree square in its angle at meridian height and a level at horizontal view.

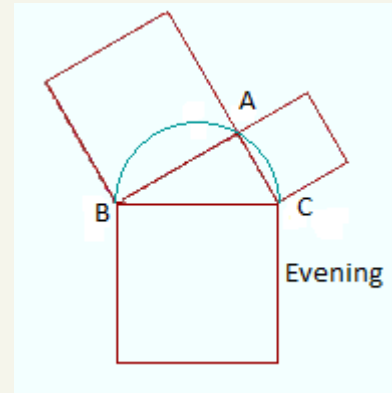
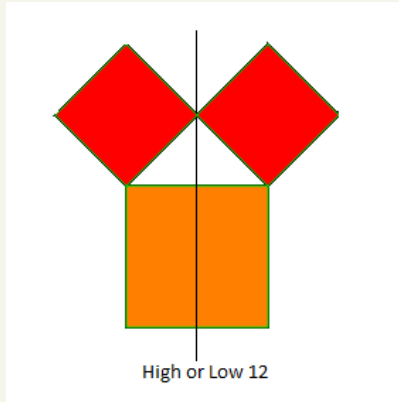
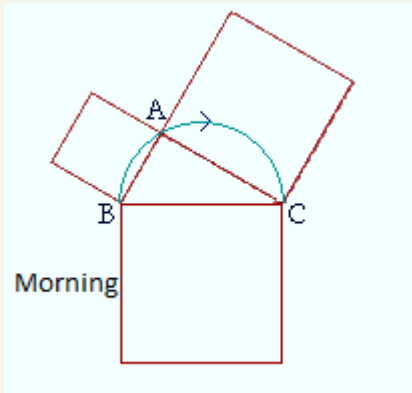

In actuality, if you fold the above aprons down, they represent the true visualization of the concept from the age of Enlightenment forward, the Earth revolves around the Sun and the right angles follow the exact same path as above but in reverse always at 90 degrees. The 90 degree point of the apron is the exact point on Earth where the Sun is traveling, as seen above at High 12. The opposite is true at night. "The lesser lights being the Sun, Moon and Worshipful Master...and as the Sun rules the day and the moon governs the night..."



So what is the significance?

Since all Lodges are in mourning of their lost Master and brethren, the bib being turned down may signify the reverential solemnity towards them and to remind us of our own immortality.

In masonic representation and teachings: the Square to the Master at always 90 degrees is the sun ruling and guiding the day or the moon ruling and governing the night; the level to the Senior Warden because when at labor it represents treating all brethren of a common spiritual faith, as occupying a status of equality and on a common level of subordination; the Plumb to the Junior Warden, because at 90 degrees and meridian height we are at the perfect criterion of rectitude and not able to sway past parallel moving forward.

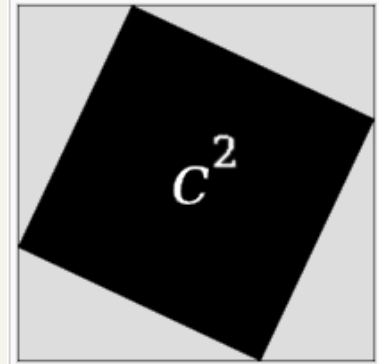
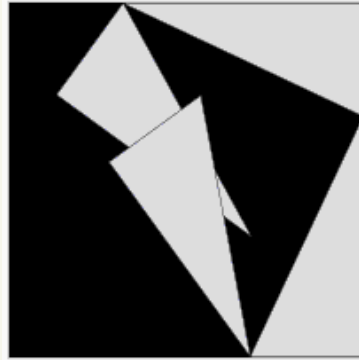
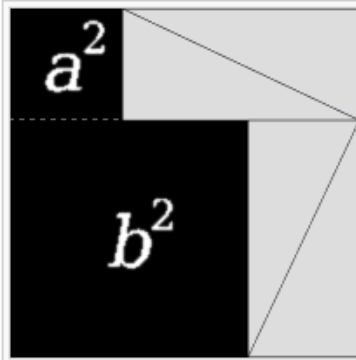

The leftmost animation consists of a large square, side $a + b$, containing four identical right triangles. The triangles are shown in two arrangements, the first of which leaves two squares a^2 and b^2 uncovered, the second of which leaves square c^2 uncovered. The area encompassed by the outer square never changes, and the area of the four triangles is the same at the beginning and the end, so the black square areas must be equal, therefore $a^2 + b^2 = c^2$.

Pythagoras in 2 dimensional plane geometry got it right pre and post Enlightenment. Whether the Sun revolves around us or we revolve around the Sun opposite measurement of angles create measured balance and equilibrium with the square being within the circle and a right angle at the heart.

(47th Problem) In every right angle triangle the square of the hypotenuse is equal to the sum of the square of the two sides. ($A^2 + B^2 = C^2$)

(48th Problem) If the square described on one of the sides of a triangle be equal to the squares described on the other sides, then the angle contained by these two sides is a right angle.

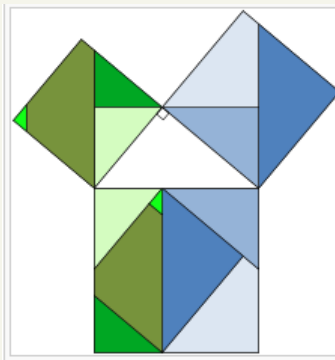

When you place all the right triangles from A and all the right angles from B together you form a perfect square C with the combination. Going back to our example of following the sun through the day: no matter what placement or angle, we are always in perfect square alignment, day or night. In life, no matter how A and B are measured or what specific qualifications they may possess, the union of their parts, in sum, always form a perfect square...

Plano Masonic Lodge #768

Ancient Free & Accepted Masons

1414½ J Avenue

Plano, TX 75074

Phone: 972-290-1357

www.PlanoMasonicLodge.org



2013-2014 SENIOR OFFICERS

Worshipful Master	Bill Goodell	214-288-1838	w.goodell@sbcglobal.net
Senior Warden	Brian Chaput	469-831-3993	chaputba1@yahoo.com
Junior Warden	Barry Parrish	214-876-6819	ellisparrish1@hotmail.com
Treasurer	Kevin Campbell	561-306-0257	kevinmcampbell2003@yahoo.com
Secretary	H. David Moore	972-380-5610	dmoore@ghizmo.com

2013-2014 JUNIOR OFFICERS

Chaplain	Jonathan Buck	469-438-5095	sbuck@cox.smu.edu
Senior Deacon	Jim Harbor	469-744-6028	jim.harbor@gmail.com
Junior Deacon	Brian Cook	972-849-1819	go2e@sbcglobal.net
Senior Steward	Shaun Henry	469-235-6141	rescue161@aol.com
Junior Steward	Dwayne Hale	972-746-0930	dhale33048@gmail.com
Marshal	Tyler Snyder		tsnyder62@gmail.com
Master of Ceremonies	Loy Vickers		pilotbiker@gmail.com
Tiler	Dennis Surrells	214-697-5682	dennis.surrells@verizon.net